

TECH TIP # 62



One of a series of dealer contractor technical advisories prepared by HARDI wholesalers as a customer service.

A Review of Basic Electrical Relationships

Voltage, Current & Resistance

To obtain a practical concept of electricity, let us consider for a moment the fluid flowing through a pipe as shown in Figure 1. You must have:

1. A pressure driving the fluid from the pipe inlet to the outlet.
2. Fluid flow through the pipe.
3. Some opposition to the flow caused by friction or restrictions in the pipe.

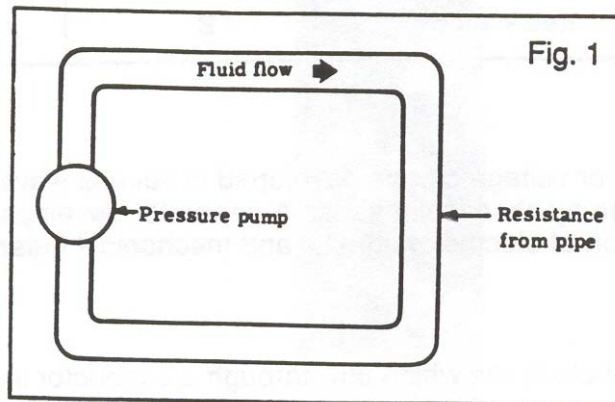

These same three “conditions” hold true for electricity, except the names and symbols are different as shown in Figure 2.

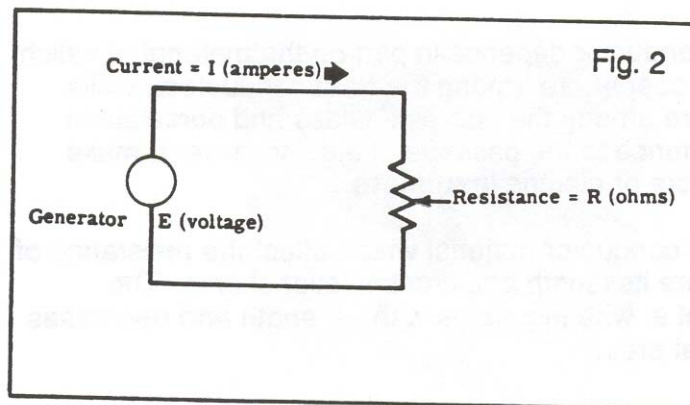

Published by the Independent Study Institute, a division of the Heating, Airconditioning & Refrigeration Distributors International. The Institute offers accredited, industry training courses in HVAC/R technology. Direct inquiries to HARDI 3455 Mill Run Drive, Ste. 820, Columbus, OH 43026. Phone 888/253-2128 (toll free) · 614/345-4328 · Fax 614/345-9161

www.hardinet.org

For electricity, you must have:

1. A pressure between the conductor inlet and outlet called a voltage.
2. Flow through the conductor called an electrical current.
3. Some opposition to the flow caused by “electrical friction” called resistance.

Table 1 lists these three electrical quantities and gives the units for each.

TABLE 1			
Quantity	Name	Symbol	Unit
Pressure	Voltage, electromotive Force (E.M.F.) or Electric Potential	E	Volt (v)
Flow	Current	I	Ampere (amp)
Friction	Resistance	R	Ohm (Ω)

Voltage

The electrical pressure or voltage can be developed in several ways. A battery develops voltage by chemical means. A generator develops voltage by a combination of electric, magnetic and mechanical means.

Current

Current is a measure of electrons which flow through a conductor in a unit of time. When current flows in one direction, it is called a direct current (DC). When current changes direction periodically, it is called an alternating current (AC).

Resistance

The resistance of a conductor depends in part on the material of which it is made. Silver and copper are among the best conductors, while glass and porcelain are among the poorest. Glass and porcelain, in presenting high resistance to the passage of electric current, make excellent nonconductors or electric insulators.

Other factors besides conductor material which affect the resistance of a conductor or wire are its length and cross-sectional area. The electrical resistance of a wire increases with its length and decreases with its cross-sectional area.

Ohm's Law

In 1827, George Simon Ohm found that the current flow (I) through a conductor was proportional to the applied voltage (E) and inversely proportional to the resistance of the circuit (R).

Although today this statement seems hardly surprising --- that is, current I goes up when the voltage E is increased and goes down when resistance R increases -- the equation expressing this relationship is the cornerstone of electricity:

$$(1) \text{ Current (I)} = \frac{\text{EMF (E)}}{\text{Resistance (R)}} \quad \text{or,}$$

$$I = \frac{E}{R}$$

The equation can be used to find resistance when the other factors are known:

$$(2) R = \frac{E}{I}$$

or when the current and resistance are known, the voltage can be found:

$$(3) E = I \times R$$

You can apply Ohm's Law to a complete circuit or to any part of it. Figure 3 shows a convenient way to remember each of the three equations, by which Ohm's Law can be expressed. We'll give an example in a moment. Cover symbol for unknown value; other two values showing are in correct relationship.

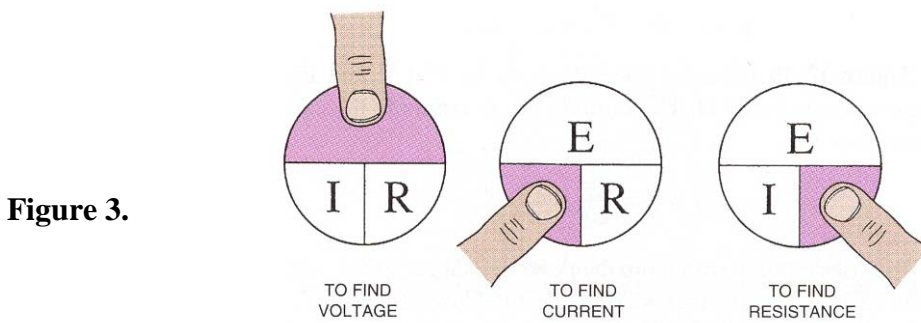

Electrical Power

When an electric current flows through a circuit, the circuit delivers “power” in the form of electrical energy, chemical energy, thermal energy, mechanical energy, etc. Thus, the passage of an electric current through a wire will result in the generation of heat or heat energy; when used to recharge a battery, it is transformed to chemical energy; when used to power a motor-driven blower, it is changed to mechanical energy.

The rate at which power is supplied to a direct-current circuit is represented by the equation:

(4) Power (P) = E x I

Power may also be expressed in other forms of equations which are shown in Figure 4.

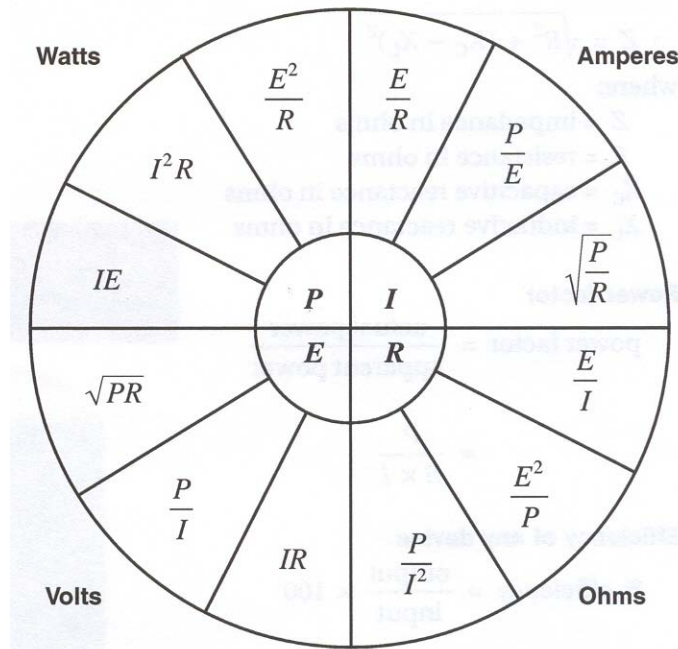

Figure 4.

The unit of power is the watt (W). One very important form of the power equation is:

(5) P = I² x R

Equation (5) shows directly the amount of electrical power delivered when current passes through a resistance. Now assume I = 2 amperes and R = 3 ohms. Using equation (5), you can find that 2 amperes of current passing through a resistance of 3 ohms will require exactly 12 watts of power (2 x 2 x 3).

What happens to this electric power? When delivered to a resistance load, it is changed from electrical energy to heat energy. If the process continues for one hour, 12 watt-hours of electrical energy will have been converted to heat energy.

Measurement

Figure 5 on the next page shows instrument connections to measure voltage, current, resistance and power. The EMF or potential present at any point in a circuit is measured by a voltmeter connected across the circuit. Current flow through the load is measured in amperes by placing an ammeter in series with the load. The direct current resistance of an electrical component can be measured by first disconnecting the component from the circuit and then using an ohmmeter across its terminals to obtain a reading in ohms.

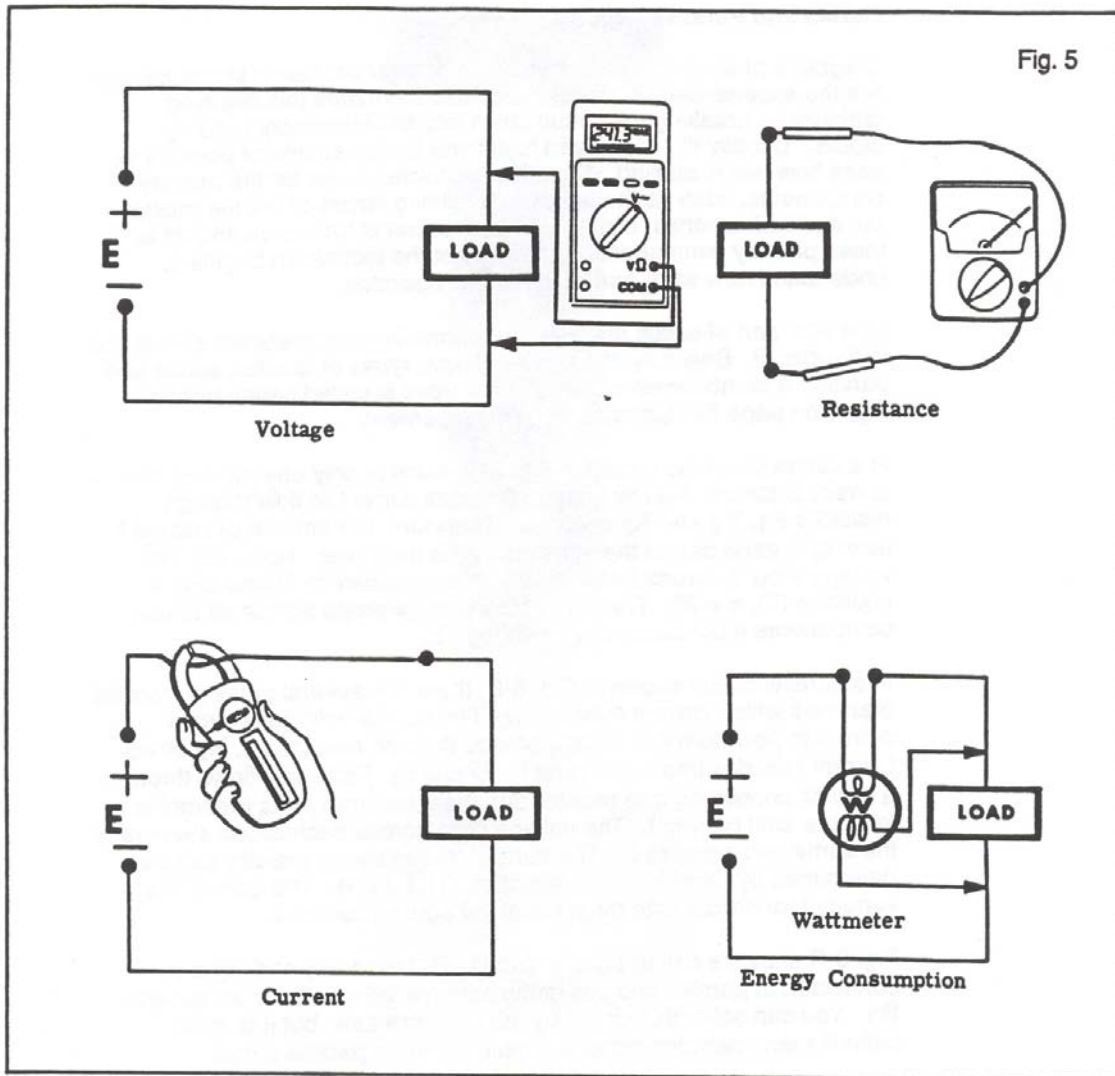

The rate of energy consumption by the load is expressed in watts and is measured with a wattmeter. Remember that watts are a rate of power consumption rather than total power consumption. Total power consumption depends upon how long power has been supplied at a certain rate and is usually measured in watt-hours or kilowatt-hours (1 kilowatt = 1000 watts).

Series and Parallel Circuits

Diagrams of electric circuits frequently appear confusing at first glance, but the experienced technician is able to overcome this seeming difficulty by breaking the circuit down into its elementary building blocks. Usually the technician looks first for the source of power and sees how this is applied. Next, the technician looks for the primary components, such as the lamps in a lighting circuit or the thermostat, fan and limit controls, etc., to see how power is turned on and off to these primary components. At this point the technician begins to understand how each part of the circuit operates.

One vital part of circuit analysis is determining how parts are connected in the circuit. Basically, there are only two types of circuits, series and parallel. A combination of these basic types is called series-parallel. Figure 6 on page 7 illustrates each arrangement.

In a series circuit as shown in Figure 6-A, there is only one path for the current to follow. Supply voltage E forces current to flow through resistors R_1 , R_2 and R_3 in series. Therefore, the amount of current I flowing in each part of the series circuit is the same. However, the voltage drop V across each resistor is determined by Ohm's Law --- equation (3), $E = I \times R$. The sum of the voltage drops across all of the components must equal source voltage E .

In a parallel circuit shown in Figure 6-B, there are several paths or parallel branches which current may follow. The source voltage E forces current to flow from the voltage source through resistor R_1 , R_2 or R_3 . Current I divides into three parts; I_1 , I_2 and I_3 . Each part flows through a branch containing one resistor and then the three parts recombine to form the total current I . The voltage drop across each circuit element is the same and equal to E . The current through each resistor can be determined by Ohm's Law --- equation (1), $I = E/R$. The sum of the various branch currents must equal the source current I .

Figure 6-C shows a series-parallel circuit. Resistors R_1 and R_2 are connected in parallel, and this combination is connected in series with R_3 . You can solve this circuit by using Ohm's Law, but it is more difficult than analyzing either a simple series or parallel circuit.

Example: In Figure 6-C assume $E = 200$ volts dc, $I = 10$ amperes, $R_1 = 20$ ohms, $R_2 = 30$ ohms and $R_3 = 8$ ohms. Find I_1 .

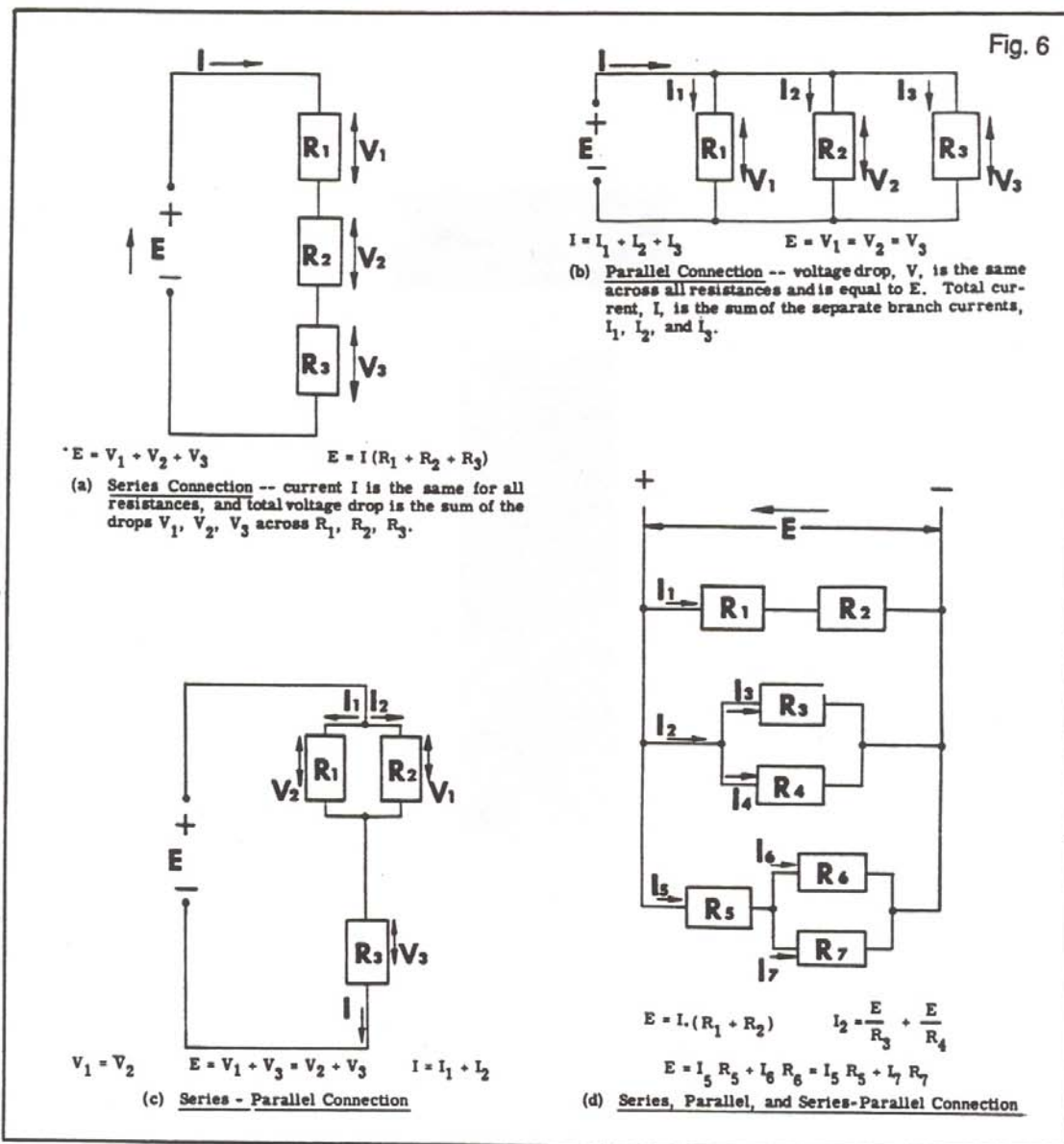

Solution: Because R_1 and R_2 are connected in parallel, the voltage drop across them must be the same. Therefore, $V_1 = V_2$. Also, we see that R_1 and R_2 are connected in parallel with each other but in series with R_3 . Therefore, $V_1 + V_3 = E$ (or we could have written $V_2 + V_3 = E$). But $V_3 = IR_3 = 10 \times 8 = 80$ volts. Therefore, the voltage drop across $R_1 = E - V_3 = 200 - 80 = 120$ volts. And since $I_1 = V_1/R_1$ we have $I_1 = 120/20 = 6$ amperes.