

TECH TIP # 56



One of a series of dealer contractor technical advisories prepared by HARDI wholesalers as a customer service.

MORE ON LADDER DIAGRAMS

To complete an electrical circuit you need a source of power, a path for the electricity to flow, and a load, such as in Figure 1 on page 4.

The source of power could be a generator, a battery, or the electrical service to the home. The flow of electricity must have a continuous path from the source and back to the source. This path is usually composed of electrical wires going from the disconnect switch through the various circuits in the furnace and back to the disconnect switch.

Also, there must be some load on the circuit to resist the flow of electricity and make use of the energy. This load can be a light bulb, a coil, or a motor; in fact anything that uses electricity. Without a load in the circuit you get a short circuit, causing electrons to flow much faster and blow a fuse.

The path for current flow can be connected in series, in parallel or a combination of the two. In a series circuit, the components are connected end to end, like rail cars on a train.

In a parallel circuit they are connected side by side across the line like rungs of a ladder. Switches and safety devices are always connected in series with the device they control. Motors and other heavy current-drawing devices are usually connected in parallel with each other.

A schematic wiring diagram has several advantages over a straight physical or pictorial-type wiring diagram, particularly for technicians. A schematic drawing is built on a ladder which allows you to determine quite easily which components are in series and which components are in parallel. With this information you can determine the interaction of component parts and see immediately what other components will not function if one component in the circuit fails.

Therefore a schematic is valuable in analyzing a failure from the circuit symptoms and it should lead you directly to the inoperative circuit and identify all of the components in that circuit.

Now I'm going to prepare you for solving schematic puzzles in future articles. And I'll start with helping you convert a physical diagram to a schematic. In the future, I'll give you the physical but you will draw the schematic version on your own.

Published by the Independent Study Institute, a division of the Heating, Airconditioning & Refrigeration Distributors International. The Institute offers accredited, industry training courses in HVAC/R technology. Direct inquiries to HARDI 3455 Mill Run Drive, Ste. 820, Columbus, OH 43026. Phone 888/253-2128 (toll free) · 614/345-4328 · Fax 614/345-9161

www.hardinet.org

Because schematics are drawn in ladder form and have no crossing lines, they read much easier than a pictorial wiring diagram, which has many lines crossing each other. As circuits become more complicated with a greater number of wires, the physical wiring diagram frequently becomes very difficult to read.

Also physical wiring diagrams don't show the actual function of the parts, but if you understand the schematic, you can convert a physical to the schematic. In other words, even though physicals and schematics look considerably different at first glance, you'll be able to use them for the same purpose.

Manufacturers draw schematics in different ways. Some draw with the source of power coming in from the top, with the components in each parallel circuit connected horizontally between the two lines. (Each parallel circuit will have components connected in series.) This form is a true ladder with the various circuits shown parallel to each other as rungs in the ladder. This type of schematic is then read from the top down.

Others draw the same type of schematic by rotating it 90° so that the source of power comes in from the left side, and the circuits are then drawn vertically connecting the two line circuits.

You read this schematic from left to right, which is more natural. For this reason, we'll type in the example.

Figure 2 is a simple physical wiring diagram for a gas upflow furnace, with cooling. It contains a disconnect, fan and limit control, single pole double throw blower relay, transformer, and blower motor in the line voltage circuit, and a gas valve, fan control and compressor contactor in the low voltage circuit. The first step in converting it to a schematic is to draw two horizontal lines showing the source of power, the disconnect switch and the fuse.

In Figure 3 the disconnect and fuse may not be shown on a physical wiring diagram because they are installed by others, but they always should be indicated on the schematic. The two arrows indicate the direction to the source of power; they do not represent current flow. Hot and neutral legs are labeled. Some wiring diagrams will call the neutral leg "ground," but remember that this is not actually an earth ground but merely the neutral side of the line when the voltage drops to zero. For this reason, I labeled it neutral rather than ground.

Most furnaces and air conditioners will contain a junction box or terminal strip for convenience in attaching the various wires. These are usually shown on a physical diagram, but are not indicated on schematics.

Go to the completed schematic (Figure 8). Follow the first series circuit from the source at the hot leg back to the source at the neutral leg. Beginning at H, follow the circuit through to the normally closed contact in the blower relay, through the blower relay to the fan control, from the fan control to the low speed terminal on the motor and then to the common on the motor back to neutral. This series circuit would be drawn as shown in Figure 4.

In Figure 8, starting from the common terminal of the blower relay another circuit is in parallel with the first circuit by going through the normally open contacts of the relay, to the high-speed tap on the blower motor, then to common of the motor and back to neutral. This circuit is drawn in Figure 5.

Another circuit in Figure 8 which is in parallel to the previous circuits goes to the limit control to the transformer and completes the line voltage wiring.

Remember that some components, like relays, connect to line voltage and the low voltage circuits. In a physical wiring diagram both the line and low voltage connections are shown located in the component. The blower relay in Figure 8 shows a low voltage coil and two line voltage contacts. In a schematic these circuits are separated with the contacts in the line voltage circuit as drawn in Figure 6 and the coil in the low voltage circuit.

The low voltage circuit is drawn in a similar manner, as described for the line voltage circuit, keeping in mind that the internal switching at the thermostat will not be shown. Thermostat terminals R, W, G and Y are in Figure 2 as well as a terminal strip which usually locates in the furnace vestibule.

One of the transformer secondary leads goes to the terminal strip at R and then to the thermostat, supplying low voltage to the thermostat. A heating control circuit from the W terminal goes to the gas valve, and then back to the other or common side of the transformer labeled C.

Another circuit in parallel to this is the blower control circuit which would run from the G terminal of the thermostat to the terminal board across to the blower relay, and back to the common side of the transformer at terminal C. A third circuit in parallel with the others is the cooling control circuit which runs from the Y terminal of the thermostat to the terminal board, then to the compressor contactor, and back to the C or common side of the transformer. This completes the schematic for both line and low voltage circuits in Figure 8.

The numbers in the physical wiring diagram Figure 2 and the schematic wiring diagram Figure 8 are the same. Identify the following components in Figure 8.

1. Blower relay
2. Fan control
3. Blower motor
4. Transformer primary
5. Transformer secondary
6. Gas valve coil
7. Blower relay coil
8. Compressor contactor coil
9. Fused disconnect

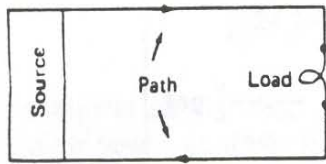

FIGURE 1

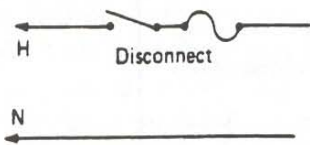

FIGURE 3

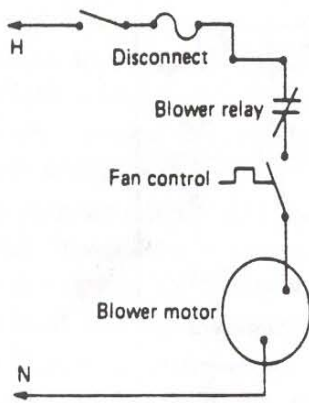

FIGURE 4

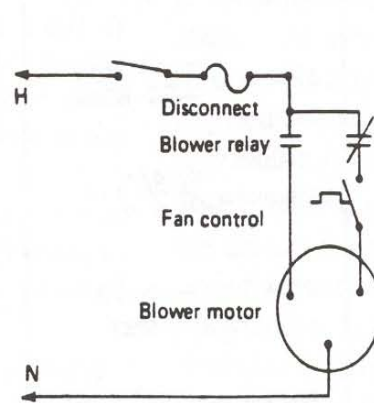

FIGURE 5

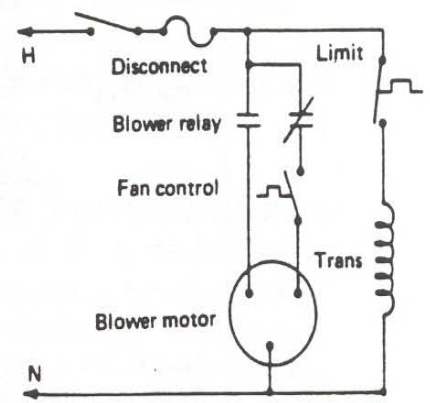

FIGURE 6

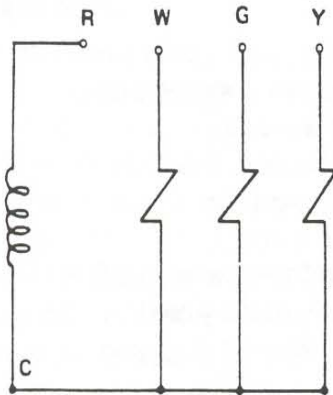

FIGURE 7

PHYSICAL WIRING DIAGRAM

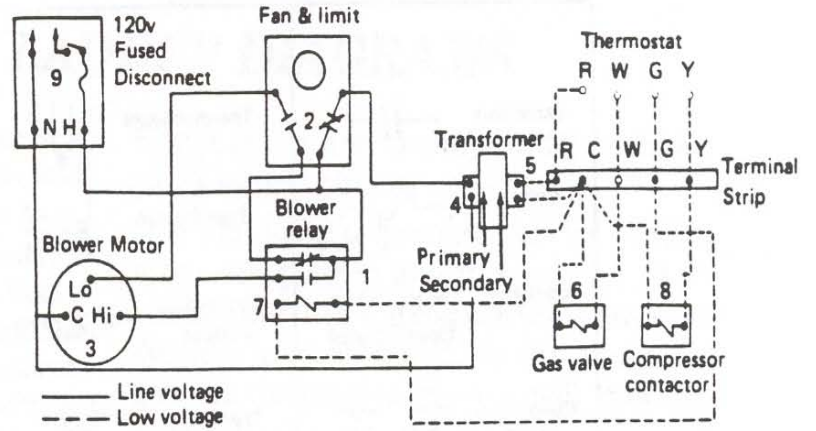

FIGURE 2

SCHEMATIC WIRING DIAGRAM

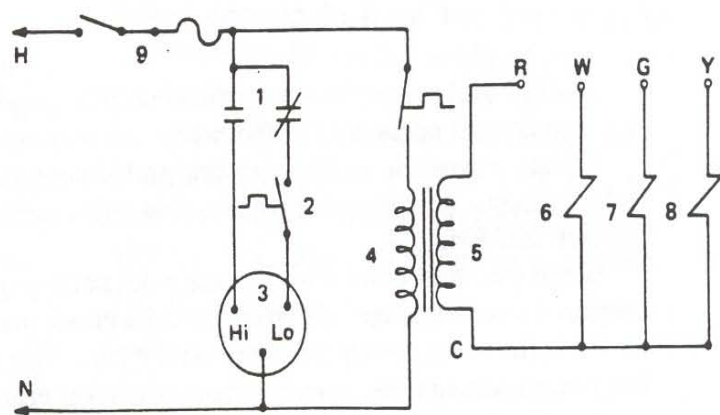
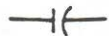

























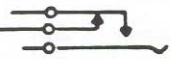
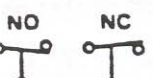



FIGURE 8

Symbols for Schematic Drawing

<p>Capacitors </p> <p>Coils </p> <p>Contacts   Open Closed</p> <p>Conductors  Crossing Junction</p> <p>Fuse </p> <p>Fusible Link </p> <p>Ground Connection </p> <p>Light </p> <p>Resistor </p> <p>Multiple Conductor Cable </p>	<p>Thermocouple </p> <p>Transformer </p> <p>Thermal overload </p> <p>Thermistor </p> <p>Connectors   Male Female</p> <p>Engaged </p> <p>4 conductor </p> <p>Switches Disconnect </p> <p>Single throw  SPST</p> <p>Double throw  SPDT</p>	<p>3 Position  SPDT</p> <p>Double pole Double throw  DPDT</p> <p>Push button  Circuit closing (make)</p> <p>Push button  Circuit opening (break)</p> <p>Push button  Two circuits</p> <p>Make before break </p> <p>Pressure  NO NC</p> <p>Temperature  Close on rising</p> <p>Temperature  Open on rising</p>
--	---	--

To draw and read schematics you should be familiar with the common symbols so that component parts are easily understood without cumbersome labeling.

Common symbols found in heating and air conditioning schematics are capacitors, coils, contacts, conductors, fuses, fusible links, ground connections, resistors, transformers and switches.

When you draw conductors, make a dot at the junction between two conductors if they are joined together. If two conductors cross and there's no dots at the junction, it means the wires merely cross but do not join. This happens with physical diagrams but not on schematics, since a schematic never cross lines.

The symbol for contacts is shown open and closed in this table and they are drawn in their normal positions. This is understood as normally open (NO) and normally closed (NC). Switches are shown the same, but the symbols for temperature switches also show whether they close or open on rising or falling temperature. A disconnect switch is shown as a single throw switch.