

TECH TIP # 10



One of a series of dealer contractor technical advisories prepared by HARDI wholesalers as a customer service.

THE DIFFERENCE BETWEEN EQUIVALENT LENGTH AND EFFECTIVE LENGTH

Equivalent length and effective length mean the same thing - - true or false?

The answer is False. Equivalent feet (or length) refer to the number of feet of straight duct that imposes the same resistance to air flow as a particular fitting.

Effective length is the SUM of the actual measured length of a duct *plus* all the equivalent lengths of the various fittings included in a particular duct run - - say from main truck to a floor diffuser.

There is hardly a design manual published which doesn't rely on *equivalent length* values for elbows, grilles, boots, and other components we call "fittings," which all go into the making of an air distribution system.

We are all aware of the fact that a duct system offers resistance to the flow of air. This resistance is overcome by the pressure exerted by the blower. Each part of the duct system, in turn, has its own resistance or pressure loss. When these are added together correctly, the pressure loss of the entire system is determined --- hence the required pressure to be imparted by the blower.

What does pressure loss have to do with equivalent length? The word *equivalent* means equal in value. Thus, equivalent length is another way of expressing pressure loss. The term came into use as an aid in simplifying design of duct systems. How do we get from pressure loss, say in terms of inches of water gauge (WG), to equivalent length?

Let's consider an elbow for example. It really doesn't matter what we use, however, for the technique is the same for grilles, boots, transitions, etc.

(continued)

Published by the Independent Study Institute, a division of the Heating, Airconditioning & Refrigeration Distributors International. The Institute offers accredited, industry training courses in HVAC/R technology. Direct inquiries to HARDI 3455 Mill Run Drive, Ste. 820, Columbus, OH 43026. Phone 888/253-2128 (toll free) · 614/345-4328 · Fax 614/345-9161

www.hardinet.org

Suppose we have a blower duct set up as shown in Fig. 1, and we can measure the static pressure before (P_1) and after (P_2) the elbow. In addition, we have a third gauge (P_3) which we can locate anywhere along the length of the duct. Let's say the duct system is made up of 7 inch round pipe - - including, of course, the elbow.

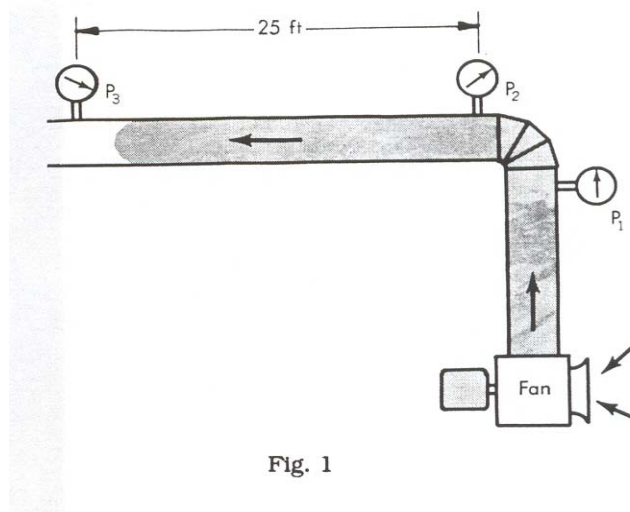

Fig. 1

With 250 cfm flowing through the system, we would find that the pressure loss of the elbow, or the difference between gauge readings P_1 and P_2 would be about 0.054 inches WG. Now to obtain the same pressure loss through the run of straight pipe between gauges P_2 and P_3 , we would find that gauge P_3 must be placed 25 feet away from gauge P_2 before the losses were the same. Thus, for the condition stated, the pressure loss of the 7 inch round elbow is equivalent to the loss of 25 ft. of 7 inch round duct.

If we increase the air flow rate through the system we would find that to keep the readings between gauges equal, we would have to move gauge P_3 further away from gauge P_2 . In other words, if we increase the flow rate to say 350 cfm, gauge P_3 might have to be placed 26 or 27 ft. away from P_2 to obtain the same loss reading as experienced by the elbow. Conversely, if we lower the flow rate, the distance between P_2 and P_3 could be narrowed. Figure 2 shows precisely how equivalent length values for this elbow vary with flow rate.

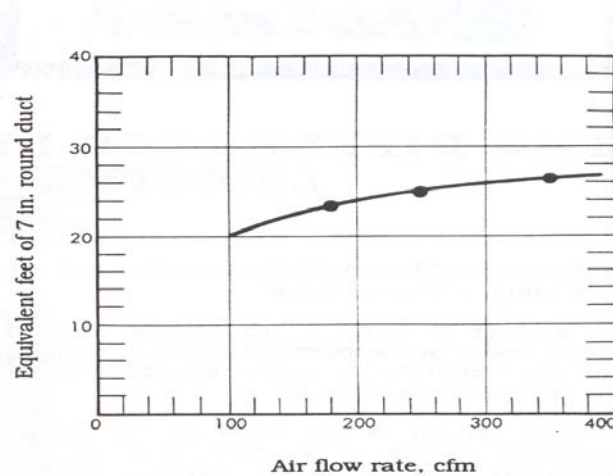

Fig. 2

A fitting's pressure loss could be expressed in terms of equivalent length of straight duct of any size. Normally, however, the diameter chosen corresponds to some nominal diameter of the fitting; for example, the collar diameter on a boot.

While equivalent length values do vary slightly with air flow rate, "average" values are normally selected to develop design procedure.

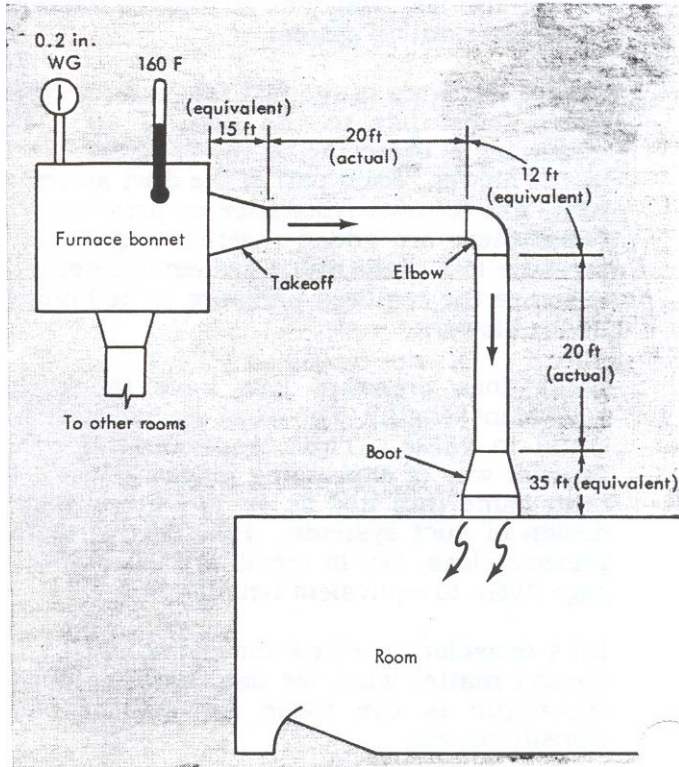

Fig. 3

To insure that the difference between equivalent and effective length is fully understood, consider Fig. 3. The measured length of straight duct from the bonnet to the room is 40 ft. (20 plus 20 ft.). The fitting equivalent lengths are 15, 12 and 35 for a total of 62 ft. The effective length of the run, therefore, are 40 plus 62 or 102 feet.

One final note, when determining duct heat loss, only actual measured duct lengths are used. Effective lengths relate strictly to pressure loss.